



EVERPURE® E-20 PREFILTER SYSTEM

PREFILTER SYSTEM FOR FOODSERVICE APPLICATIONS

E-20 Prefilter System: EV9795-90
Everpure EC210 Prefilter Cartridge: EV9534-26



APPLICATIONS

Foodservice Applications
Requiring Prefiltration
High Sediment Areas

FEATURES • BENEFITS

Filters out larger dirt and rust particles
Durable slim bowl design makes cartridge
change outs easy to handle
Extends the life of primary filter cartridges
20" bowl design accepts most 20" drop
in cartridges
Tightly spun Everpure EC210 sediment
cartridge delivers 10-micron nominal
filtration

INSTALLATION TIPS

Choose a mounting location suitable to support the full weight of the system when operating.
Make sure to properly lubricate o-ring prior to use.
Use 3/4" water line (optional reducer bushings included).
Install vertically with bowl hanging down.
Allow 2 1/2" (6.35 cm) clearance below the cartridge for easy cartridge replacement.

OPERATION TIPS

Inspect Everpure EC210 cartridge periodically to determine dirt load.
Replace Everpure EC210 cartridge when dirt has penetrated through to the inner core of the cartridge.
Do not exceed service flow rate.
Inspect o-ring during each cartridge change. Lubricate and/or replace if necessary.

SIZING

Service Flow Rate: Maximum 8.0 gpm
(30.3 Lpm)

EVERPURE® E-20 PREFILTER SYSTEM

EV9795-90

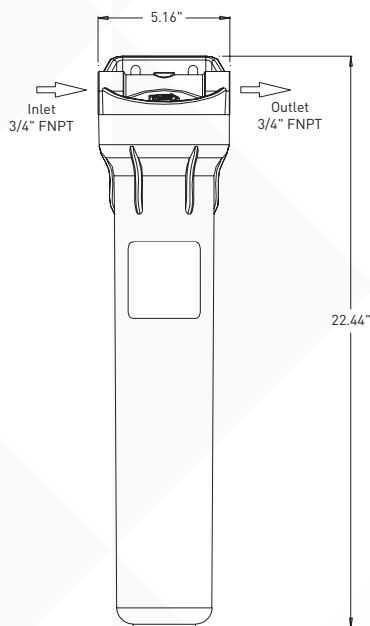

The contaminants or other substances removed or reduced by this drinking water system are not necessarily in your water. Do not use with water that is microbiologically unsafe or of unknown quality without adequate disinfection before or after the system.

SPECIFICATIONS

Service Flow Rate

Maximum 8.0 gpm (30.3 Lpm)

Pressure Requirements

10–125 psi (0.7–8.6 bar), non-shock

Temperature

35–00°F (2–38°C)

Overall Dimensions

22.44" H x 5.16" W x 5.5" D
(56.9 cm x 13.1 cm x 13.9 cm)

Inlet Connection

3/4"

Outlet Connection

3/4"

Operating Weight

8 lbs (3.6 kgs)

Shipping Weight:

6 lbs (2.7 kgs)

Electrical Connection

None required

WARRANTY

Everpure water treatment systems by Pentair® (excluding replaceable elements) are covered by a limited warranty against defects in material and workmanship for a period of five years after date of purchase. Everpure replaceable elements (filter cartridges and water treatment cartridges) are covered by a limited warranty against defects in material and workmanship for a period of one year after date of purchase. See printed warranty for details. Pentair will provide a copy of the warranty upon request.



WATER QUALITY SYSTEMS

EVERPURE-SHURFLO WORLD HEADQUARTERS, 1040 MUIRFIELD DRIVE, HANOVER PARK, IL 60133 USA • FOODSERVICE.PENTAIR.COM
800.942.1153 (US ONLY) • 630.307.3000 MAIN • 630.307.3030 FAX • CSEVERPURE@PENTAIR.COM EMAIL

EVERPURE-SHURFLO AUSTRALIA, 1-21 MONASH DRIVE, DANDENONG SOUTH, VIC 3175 AUSTRALIA
011.1300.576.190 TEL • 011.61.39.562.7237 FAX • AU.EVERPURE@PENTAIR.COM EMAIL

EVERPURE-SHURFLO CHINA, 21F CLOUD 9 PLAZA, NO 1118, SHANGHAI, 200052, CHINA
86.21.3211.4588 TEL • 86.21.3211.4580 FAX • CHINA.WATER@PENTAIR.COM EMAIL

EVERPURE-SHURFLO INDIA, GREEN BOULEVARD, B-9/A, 7TH FLOOR - TOWER B SECTOR 62, NOIDA - 201301
91.120.419.9444 TEL • 91.120.419.9400 FAX • INDIACUSTOMER@PENTAIR.COM EMAIL

EVERPURE-SHURFLO EUROPE, PENTAIR WATER BELGIUM BVBA, INDUSTRIEPARK WOLFSTEE, TOEKOMSTLAAN 30, B-2200 HERENTALS, BELGIUM
+32.(0).14.283.504 TEL • +32.(0).14.283.505 FAX • SALES@EVERPURE-EUROPE.COM EMAIL

EVERPURE-SHURFLO JAPAN INC., HASHIMOTO MN BLDG. 7F, 3-25-1 HASHIMOTO, MIDORI-KU, SAGAMIHARA-SHI KANAGAWA 252-0143, JAPAN
81.(0)42.775.3011 TEL • 81.(0)42.775.3015 FAX • INFO@EVERPURE.CO.JP EMAIL

EVERPURE-SHURFLO SOUTHEAST ASIA, 390 HAVELOCK ROAD, #04-01 KING'S CENTRE, SINGAPORE 169662
65.6768.5800 TEL • 65.6737.5149 FAX • CSEVERPURE@PENTAIR.COM EMAIL

Pentair trademarks and logos are owned by Pentair plc or its affiliates. Third party registered and unregistered trademarks and logos are property of their respective owners. Because we are continuously improving our products and services, Pentair reserves the right to change specifications without prior notice. Pentair is an equal opportunity employer.